

Understanding how it works

Each radio has 4 call sign fields to be programmed. What you need to know to program a radio is:

Operating frequency	Simplex or Duplex frequency
MyCall	Your call sign (primary operator)
UrCall	Call sign of the person / zone being called
Rpt1	1 st repeater
Rpt2	2 nd repeater

Understanding how it works (Simplex)

To complete a local simplex call, program 2 fields along with the frequency in the radio.

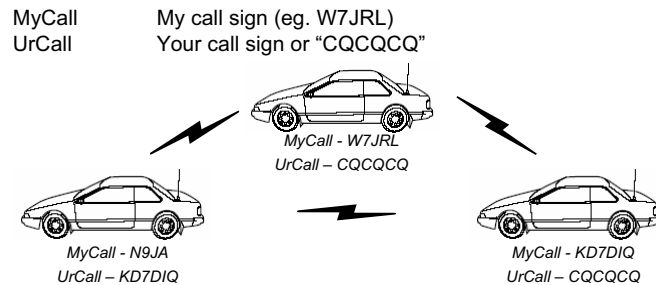

Understanding how it works (Simplex)

In this example, all parties in digital mode hear all the traffic on the simplex channel.

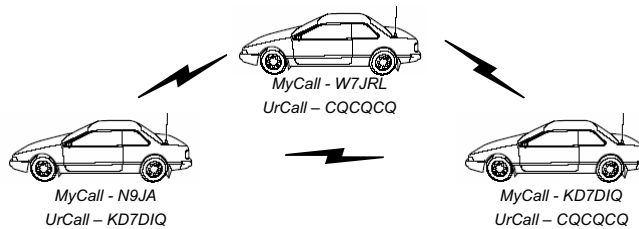

Understanding how it works (Repeater)

To complete a *local zone* repeater call, program 3 fields along with the frequency in the radio.

MyCall	My call sign (eg. W7JRL)
UrCall	Your call sign or "CQCQCQ"
Rpt1	Local repeater call sign

Understanding how it works (Repeater)

When you program your radio's "RP1" location, and the proper frequency, your radio tells the desired repeater to activate. This is similar to PL tones in analog.

Eg. MyCall	W7JRL
RPT1	N7IH A
UrCall	CQCQCQ
RPT2	nothing

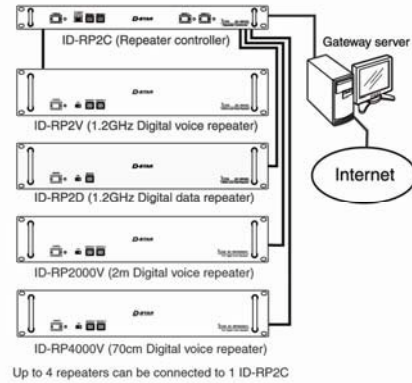

N7IH Repeater



Understanding how it works (Repeater)

Eg. MyCall	W7JRL
RPT1	N7IH A
UrCall	CQCQCQ
RPT2	nothing

In this example, the N7IH repeater would activate on the repeater frequency you were transmitting on (1.2GHz).

(In this example, we are using the ID-1 radio.)

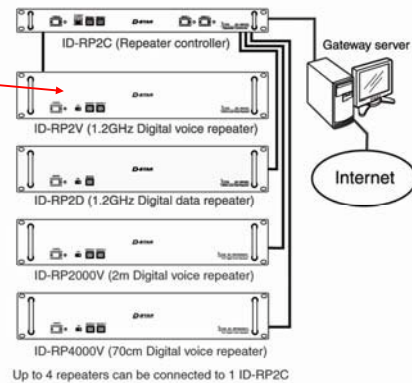

N7IH Repeater



Understanding how it works (Repeater)

All parties on the local repeater channel will hear all the local radio traffic on that frequency.

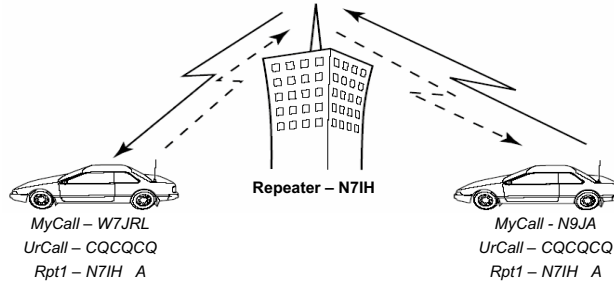

Understanding how it works (Gateway)

To complete a gateway repeater call, program all 4 call sign fields within the radio.

Repeater must be connected to a gateway server PC.

MyCall	My call sign (eg. W7JRL)
UrCall	Your call sign or "/ zone" and module (eg. /K5TIT A)
Rpt1	Local repeater call sign
Rpt2	Local repeater + "G" as the 8 th letter (eg. N7IH G)

Understanding how it works (Repeater)

Eg. MyCall W7JRL
RPT1 N7IH A
 UrCall /K5TIT
 RPT2 N7IH G

In this example, the N7IH repeater would activate on the repeater frequency you were transmitting (1.2GHz) and then...

(In this example, we are using the ID-1 radio.)

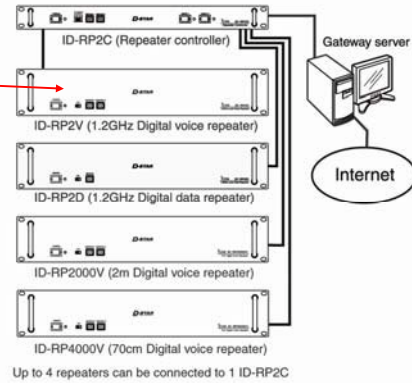

N7IH Repeater



Understanding how it works (Repeater)

Eg. MyCall W7JRL
RPT1 N7IH A
 UrCall /K5TIT
RPT2 N7IH G

routed to the gateway and directed to the proper remote repeater through the internet.

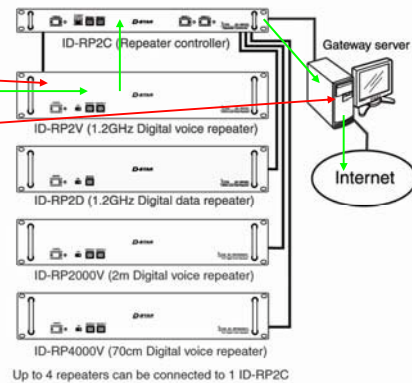

N7IH Repeater



Understanding how it works (Repeater)

Eg. MyCall W7JRL
 RPT1 N7IH A
UrCall **/K5TIT**
 RPT2 N7IH G

The gateway is told where to route the call based on what is in the "UrCall" field of the radio.

/K5TIT tells the gateway to route the call to the K5TIT repeater. The "/" means "zone call".

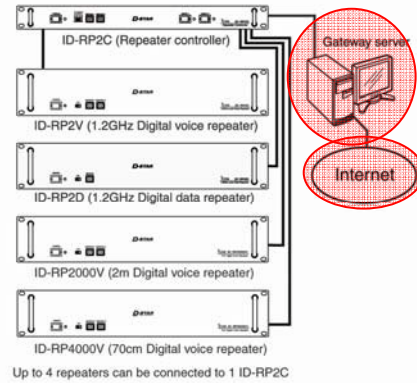

N7IH Repeater



Understanding how it works (Gateway)

Using "/" in front of the repeater call sign in the "UrCall" field activates that "zone" (module) at the remote repeater.

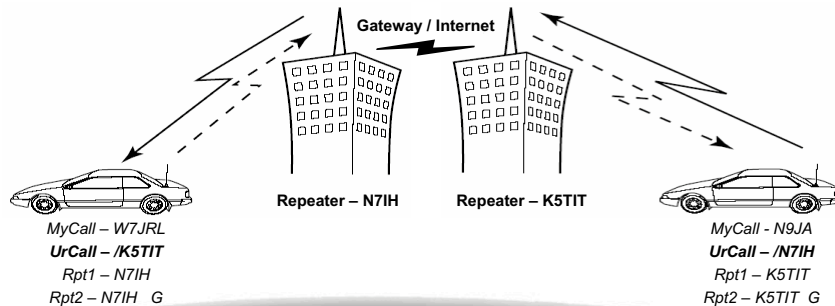

Understanding how it works (Repeater)

Eg. MyCall W7JRL
 RPT1 N7IH A
UrCall /K5TIT ?
 RPT2 N7IH G

Since we did not designate a "module" in the "UrCall" field, the system automatically routes to the "A" module of the remote repeater (K5TIT).

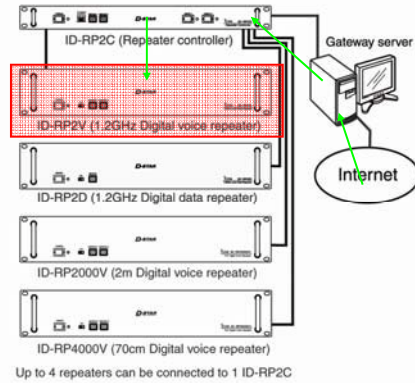

K5TIT Repeater



Understanding how it works (Repeater)

Eg. MyCall W7JRL
 RPT1 N7IH A
UrCall /K5TIT **C**
 RPT2 N7IH G

If we add the "designator" as the 8th letter, we can route to different modules at the remote repeater site.

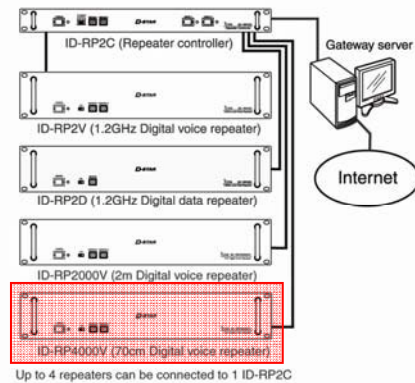

K5TIT Repeater



Understanding how it works (Repeater)

Eg. MyCall W7JRL
 RPT1 N7IH A
UrCall /K5TIT
 RPT2 N7IH G

Currently, you are *not able* to activate more than 1 module at the remote repeater site.

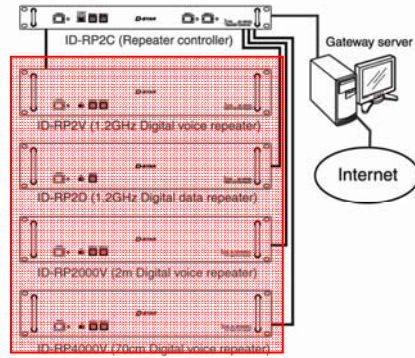

Up to 4 repeaters can be connected to 1 ID-RP2C

K5TIT Repeater



Understanding how it works (Repeater)

Eg. MyCall W7JRL
 RPT1 N7IH A
UrCall N9JA
 RPT2 N7IH G

If you use the call sign of the person you wish to call, the gateway automatically routes the call to the last known location of that call sign within the repeater network.

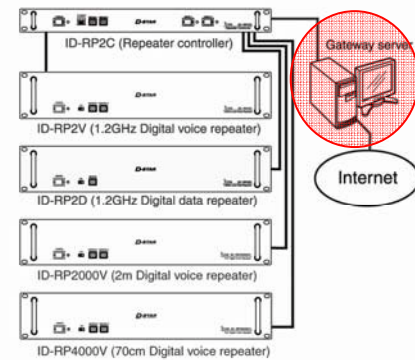

Up to 4 repeaters can be connected to 1 ID-RP2C

N7IH Repeater



Understanding how it works (Gateway)

Using the call sign of the desired party to be reached in the "UrCall" field automatically routes to wherever the radio was last heard.

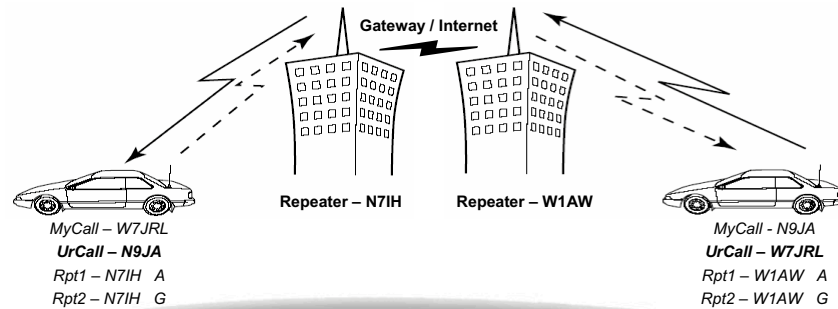

Understanding how it works (Gateway)

In both examples, all parties on the local repeater and remote repeater hear all the radio traffic on the frequency.

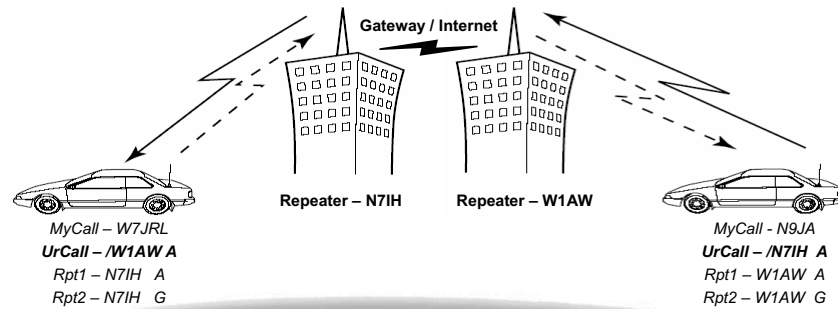

Understanding how it works (Gateway)

Both radios must be properly programmed to operate via the gateway in order for transmissions to be heard both directions.

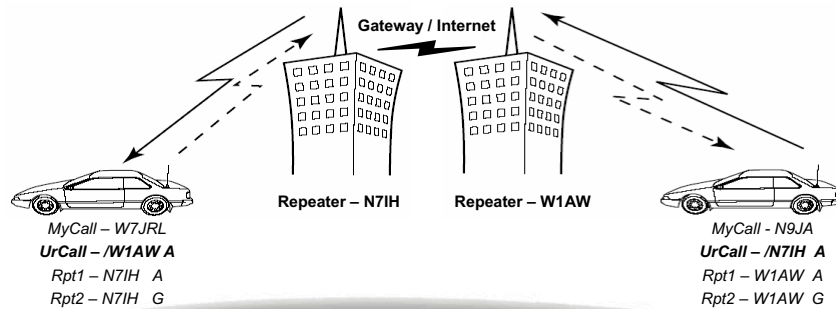

Understanding how it works (Gateway)

In this example, N9JA would hear W7JRL's transmission but, W7JRL would not hear N9JA since no gateway is selected.

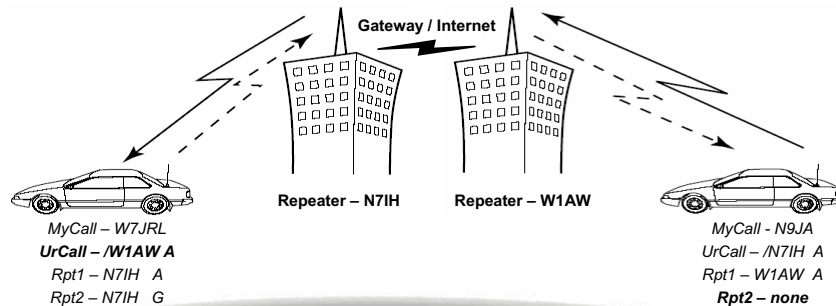

Understanding how it works (Repeater)

To complete a *cross-band* (*cross-module*) repeater call, program all 4 call sign fields within the radio. Repeater must have multiple voice modules installed.

MyCall	My call sign (eg. W7JRL)
UrCall	Your call sign or "CQCQCQ"
Rpt1	Local repeater input module call sign (eg. N7IH A)
Rpt2	Local repeater output module as the 8 th letter (eg. N7IH C)

Signal is repeated on both input and output frequencies / modules locally.

Understanding how it works (Repeater)

Eg.

MyCall	W7JRL
RPT1	N7IH A
UrCall	CQCQCQ
RPT2	N7IH C

When using the designator of another local module in the "RPT2" field, the call is routed to that module locally.

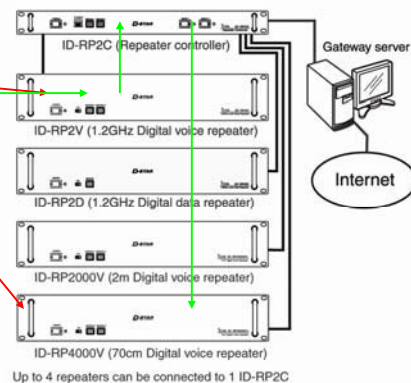

N7IH Repeater

Understanding how it works (Repeater)

In this example, all parties listening on 1.2GHz and 440MHz would hear all radio traffic.

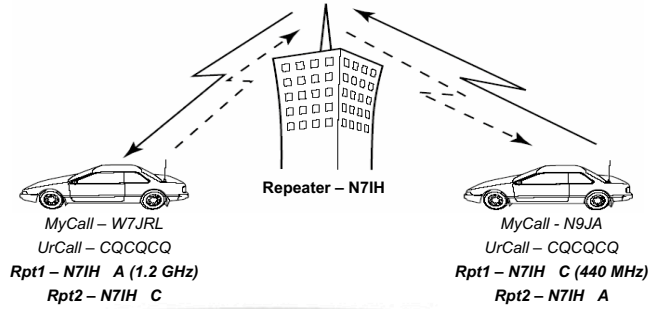

Understanding how it works (Repeater)

In this example, W7JRL would not hear N9JA reply because he is not properly programmed for cross-band operation.

